



IRP100 7Axis Ballscrew

Product Specification - Version 2, Release 6



Zeeko Ltd.

Rev. 08.12.14

Contents

1	Machine Description	2
2	Arrangement of the Axes	3
3	Polymer Granite Machine Base	4
4	Linear Axes.....	5
5	Rotary Axes & Spindles	6
6	Machine Enclosures.....	8
7	Control Systems	9
8	Guards, Covers & Safety Features	10
9	Chiller Unit	11
10	Micro Slurry Management Unit (SMU).....	12
11	ZeekoJet Polishing	13
12	Summary Specification.....	15
	12.1 General	15
	12.2 Linear Axes.....	15
	12.3 Rotary Axes.....	16

1 Machine Description

The IRP 100 is a 7 axis CNC optical polishing machine capable of producing ultra-precise finishes on a variety of complex surface forms on hard materials (such as ceramic substrates). The machine axes can be used for either spiral or raster tool paths using the Zeeko Classic style of polishing.

- ❖ Mass = 1500 Kg
- ❖ Dimensions = 1000 x 1375 x 2050 (W x D x H mm)

The machine frame is a welded steel structure incorporating the following features:

- ❖ 4 point floor mounting.
- ❖ Integrated electrical and pneumatics enclosures.
- ❖ Integrated Slurry Management System.
- ❖ Integrated chiller unit.
- ❖ 3 point mounting for polymer-granite base.
- ❖ Slurry unit enclosure below base.

The machine base is a precision cast and ground polymer-granite composite structure that provide excellent thermal stability and vibration damping characteristics. This key structural machine elements incorporates the following features:

- ❖ Threaded inserts and moulded alignment features for X axis and virtual pivot assembly mounting.
- ❖ Moulded feed-through for slurry drainage.

2 Arrangement of the Axes

The arrangement and definition of the 7 CNC axes is as follows:

- ❖ X is a linear axis which mounts horizontally to the polymer-granite base. The X axis carriage is a precision machined stainless steel structure.
- ❖ Y is a linear axis is a precision machined stainless steel structure which mounts vertically to the X axis carriage and aligned perpendicular to the X axis.
- ❖ Z is a linear axis is a precision machined stainless steel structure which mounts horizontally to the Y axis and is aligned perpendicular to both the X and Y axes.
- ❖ C is a rotational axis that holds the work piece. It is mounted in line with the Z axis.
- ❖ A, B and H are rotational axes configured such that the polishing head (H axis) rotates through a point in space called the Virtual Pivot (VP). This three axes assembly mounts to the polymer-granite base.

3 Polymer Granite Machine Base

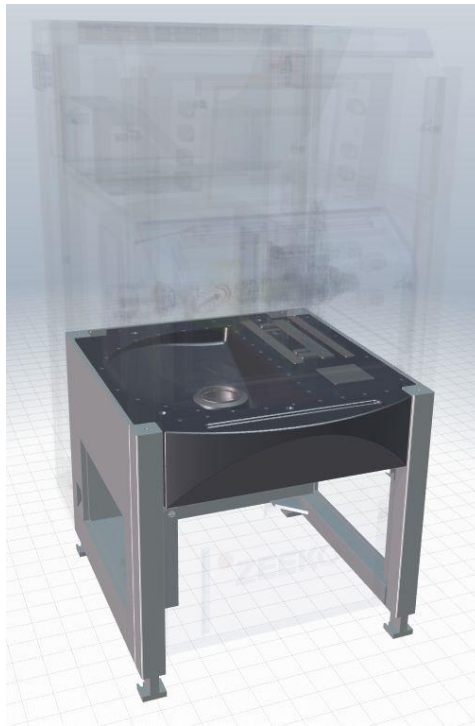

Figure 1: Polymer Granite Base & Welded Steel Frame

The machine base is precision cast and machined polymer-granite composite structure that provides excellent thermal stability and vibration damping characteristics. This key machine element incorporates the following features:

- ❖ Moulded-in stainless steel inserts for mounting and alignment of the X axis, handling, and transportation.
- ❖ Threaded stainless steel inserts for mounting the polishing and electrical enclosures.
- ❖ Moulded-in feeds for electrical supply and control cables, compressed air, and slurry supply and return.

4 Linear Axes

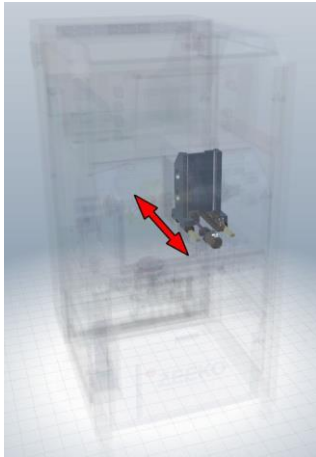

Figure 2: X Axis

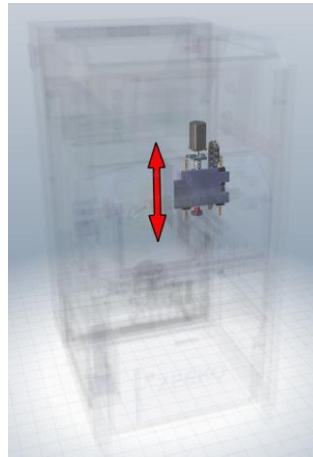

Figure 3: Y Axis

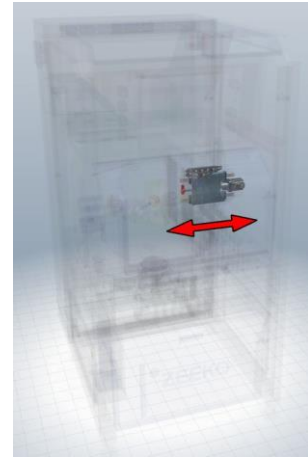

Figure 4: Z Axis

Each axis is mounted on a pair of precision THK linear motion rails and driven via precision ground ballscrews. Position feedback is provided by the use of AC Servo absolute rotary motor encoders.

The X Axis has an asymmetric range of +60mm to -100mm to facilitate operator loading and unloading of the work piece.

- ❖ Slide type: THK linear motion rails
- ❖ Travel (X Axis): -100mm to +60mm
- ❖ Travel (Y Axis) $\pm 60\text{mm}^1$
- ❖ Travel (Z Axis) 100mm
- ❖ Drive system: AC servo driven precision ground ballscrew.
- ❖ Positioning feed-back: AC servo integral absolute encoder
- ❖ Max velocity: 3000mm/min

¹ Y-Axis travel may be limited at X-Axis travel limits

5 Rotary Axes & Spindles

The A,B & H axes provide the primary tool motions and are often referred to as the Virtual Pivot (VP). The VP is mounted directly to the polymer-granite base.

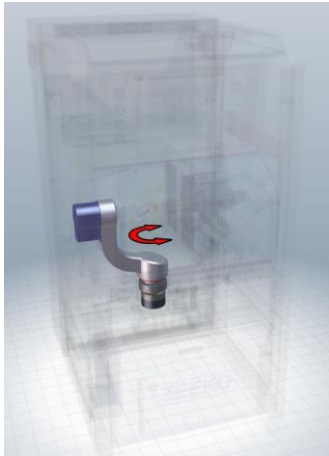

Figure 5: A Axis

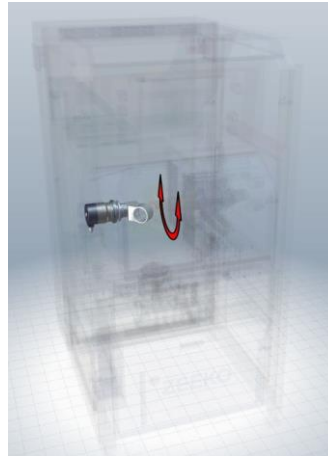

Figure 6: B Axis

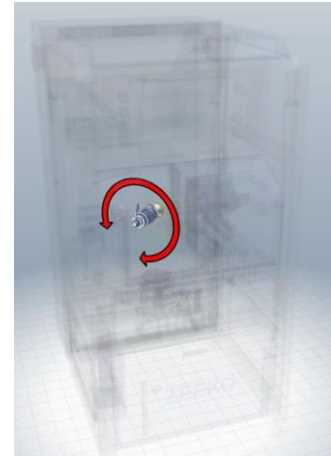

Figure 7: H Axis

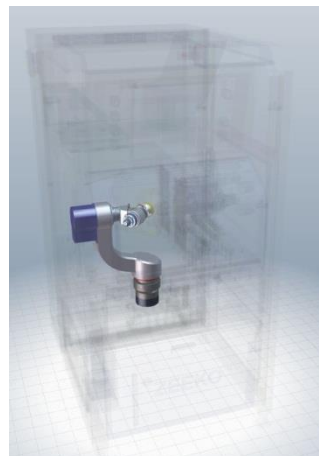

Figure 8: VP Assembly (A,B & H)

The A axis is mounted to the Base via an AC servo drive Harmonic Drive unit with enhanced radial stiffness. Referencing of the position is via a non-contact referencing element. Referencing is only required following power up of the machine.

- ❖ Rotational Range: -55° to $+110^{\circ}$
- ❖ Max Rotational Velocity: 40rpm

The B axis is mounted to the A axis via AC servo driven Harmonic Drive unit. Referencing of the position is via a non-contact referencing element. Referencing is only required following power up of the machine.

- ❖ Rotational Range: $\pm 180^{\circ}$
- ❖ Max Rotational Velocity: 40rpm

The H axis forms the tool holding spindle and is mounted to the A/B axes and completes the virtual pivot assembly. Drive is provided via a DC frameless motor with position feedback from rotary encoder. Tooling mounts via a $\varnothing 12\text{mm}$ hydrodehn

IRP100 7Axis Ballscrew

Product Specification

chuck. The H axis also integrates a load cell arrangement to facilitate part probing essential for process stability and part/machine referencing.

- ❖ Speed Range: 10 to 3000rpm
- ❖ Polishing Head radii: Solid or Inflatable R20, R40, solid R10 (standard) (Solid R5, Optional)

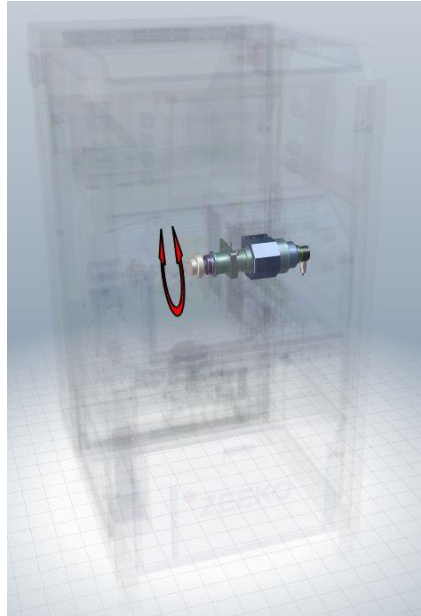

Figure 9: C Axis/Spindle

The C Axis forms the work piece mounting spindle and is mounted to the X-Y-Z Axes. The axis consists of rolling element bearings driven by a Brushless DC servo motor, with positional feedback provided by a precision absolute encoder.

The Spindle is supplied with a Ø25mm Hydrodehn chuck for work piece mounting.

- ❖ Speed Range: 0 to 1000rpm
- ❖ Max Load Capacity: 4.5Kg

6 Machine Enclosures

The Machine enclosures provide for the following:

- ❖ Coated stainless steel polishing enclosure (Internal surfaces).
- ❖ Machine electrical and pneumatic systems.
- ❖ Maintenance access to X, Y, and Z slides.
- ❖ Transit constraints.

7 Control Systems

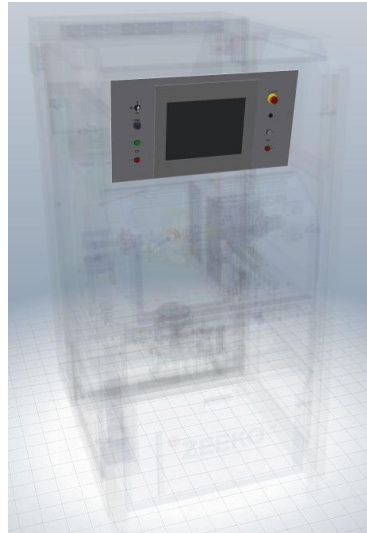

Figure 10: Control Console

- ❖ 2GHz Celeron processor, 1MB RAM
- ❖ Rexroth MTX controller
- ❖ 5 axis interpolation via individual digital drive controllers
- ❖ 15" colour TFT LCD with touch panel screen
- ❖ Multi-axis NURBS interpolation
- ❖ Ethernet port for data I/O and/or remote diagnostics / maintenance
- ❖ USB socket



Zeeko reserves the right to fit either an Indradrive version of this control system specification, or an Ecodrive version of the system and warrants the performance of both systems as identical



The Bosch Drive system used is subject to upgrades without prior approval by Zeeko and so this spec sheet may require updating at short notice as there is a new "SERCOS 3" Controller due to be introduced by Bosch shortly

8 Guards, Covers & Safety Features

The equipment specified herein shall conform to requirements of EC and international safety regulations as required by current legislation.

Cover and guards will be provided to protect the operator from:

- ❖ Moving machine parts
- ❖ Slurry and spray
- ❖ Covers will also protect machine elements from:
 - ❖ Slurry and fluids used in the polishing enclosure
 - ❖ Airborne dust and debris

The following will be prevented from opening:

- ❖ The polishing enclosure door when the machine is in automated motion.
- ❖ Electrical cabinet when the machine is energised.
- ❖ MicroSMU when machine is in automated mode.

Motors in MicroSMU are prohibited to start when MicroSMU is open.

An emergency stop button readily accessible to the machine operator.

9 Chiller Unit

A Refrigerated 19" Euro-rack mounted de-mineralised water cooler is supplied integral to the machine and is used to chill both the C axis and the Slurry (SMU versions only).

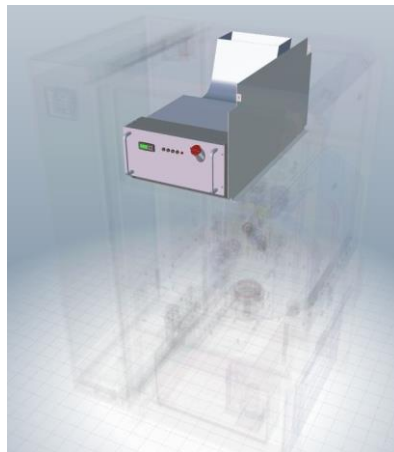

Figure 11: Integrated Chiller System

- ❖ Heat capacity 30°C ambient air: 540W@20°C water temp.
- ❖ Max. heat rejection to air 620 W
- ❖ Design fluid temperature 15 to 25°C
- ❖ Ambient air temp. range 15 to 40° C
- ❖ Control accuracy $\pm 0.75^{\circ}\text{C}$
- ❖ Capacity control Compressor on/off
- ❖ Fluid De-mineralised water
- ❖ Tank capacity 3.6 litres

10 Micro Slurry Management Unit (MicroSMU) - Optional

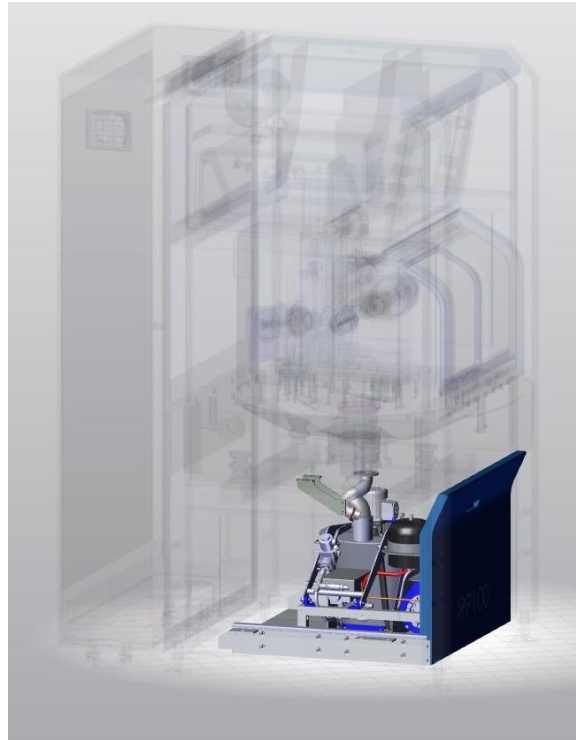

Figure 12: Integrated MicroSMU

- ❖ Max Flow Rate:
 - ⊕ 30 L/min – Standard Low Pressure Pump
 - ⊕ 8.7 L/min –High Pressure Pump for ZeekoJet Polishing
- ❖ Pressure Variation: ± 2%
- ❖ Tank Capacity: 15 Litres

11 Peristaltic Pump System - Optional

The Zeeko externally mounted peristaltic slurry delivery system can be used to supply polishing slurry in either a closed loop or open loop, total loss system.

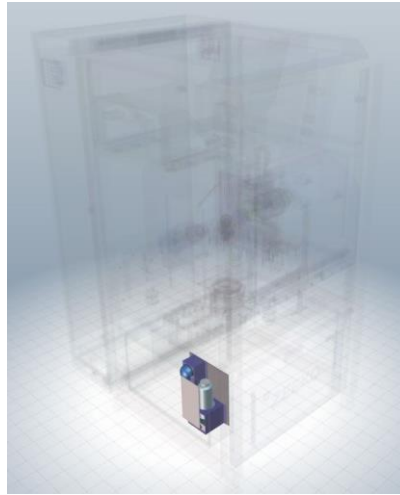

Figure 13: Peristaltic Pumping System

High flow rate Pump specification (recirculating or total loss):

- Flow rate: Min flow rate: 75ml/min
 Max flow rate: 280ml/min
- Reservoir capacity: 1 litre
- Tube Type: Ø4.8mm Masterflex PharMed BPT
 Long life, high acid/alkali resistance
- Agitation method: Magnetic stirrer.

Low flow rate pump specification (recirculating or total loss):

- Flow rate: Min flow rate: 8ml/min
 Max flow rate: 30ml/min
- Reservoir capacity: 1 litre
- Tube Type: Ø1.6mm Masterflex PharMed BPT
 Long life, high acid/alkali resistance

Agitation method: Magnetic stirrer.

12 ZeekoJet Polishing

H-axis is a 'combo head' capable of Classic polishing and additionally Fluid Jet Polishing (FJP). FJP specification is as follows:

- ❖ Bonnet and hydrodehn chuck are removed and optional FJP adaptor is assembled. Adaptor has removable probe for probing routines.
- ❖ Nozzle bore range available: 0.25, 0.5, 1.0, 1.5mm
- ❖ Maximum rated pressure is 20bar.
- ❖ 4mm piping (minimum) through H-axis maximises slurry flow rate.

13 Summary Specification

13.1 General

General	Description
System Configuration	7 Axis CNC Optical Polishing Machine constructed on Polymer Quartzite Machine Base, capable of producing ultra-precise surfaces on a variety of optical materials and surface forms.
Work piece Capacity	Nominal polishing envelope of 100x100x100mm
Base Structure	Polymer Granite
Control System	Bosch MTX
Dimensions (No Accessories) WxDxH	1080mm x 1475mm x 2030mm
Suggested Install Dimensions	2700mm x 3200mm x 2530mm
Weight	1500Kg
Floor Load Requirements	Minimum loading 140,000Kg/m ² Floor must be even to <3mm/m ²
Environmental Requirements Min/Max Operating Temp. Max Operating Humidity Min/Max Storage Temp. Max Storage Humidity	15°C - 35°C (<2°C/hour Temperature Gradient) 75% RH Non Condensing -15°C - 50°C 80% RH Non Condensing
Power Supply Requirements	3Phase+N+E, 200VAC 50/60Hz 3KW
Services Requirements	Clean dry air at 185L/min with minimum pressure of 6bar, Mains water for MicroSMU cleaning cycle
Noise Level	<50bB(A) Continuous
Safety	In accordance with EC Directives 2006/42/EC, 2004/108/EC (EMC) and 2006/95/CE (Low Voltage)

13.2 Linear Axes

Description	X	Y	Z
Slide Type	THK Linear Motion Rails	THK Linear Motion Rails	THK Linear Motion Rails
Drive Type	Servo Driven Ø16-5 precision ground ballscrew	Servo Driven Ø16-5 precision ground ballscrew	Servo Driven Ø16-5 precision ground ballscrew
Feedback Type	Absolute Rotary Encoder	Absolute Rotary Encoder	Absolute Rotary Encoder
Travel	+60 to -100mm	±60mm	+5mm , -95mm Max VP-Chuck Face Distance= 101mm Min VP-Chuck Face Distance=1mm
Max Velocity	3000mm/min	3000mm/min	3000mm/min
Max Acceleration	250mm/sec ²	250mm/sec ²	250mm/sec ²
Positioning Accuracy	<10µm over full travel	<10µm over full travel	<10µm over full travel
Bi-direction Repeatability	<5µm	<5µm	<5µm
Straightness: Horizontal: Vertical:	<10µm over full travel <10µm over full travel	<10µm over full travel <10µm over full travel	<10µm over full travel <10µm over full travel
Squareness	<50µ/m	<50µ/m	<50µ/m
Circularity	<50µm	<50µm	<50µm

IRP100 7Axis Ballscrew

Product Specification

13.3 Rotary Axes

Rotary Axes	A	B	H (Tool)	C (Workpiece)
Mounting	Polymer Granite Base	A Axis Arm	Virtual Pivot Assembly	Z Axis Carriage
Spindle/Axis	Axis	Axis	Spindle	Spindle & Axis
Cooled	Not Req'd	Not Req'd	No	Yes
Integral Services	N/A	N/A	Air (STD)/FJP (Optional)	Vacuum (Optional)
Probing	N/A	N/A	125N Load Cell	N/A
Drive	Gear Driven Servo drive with enhanced radial stiffness	Gear Driven Servo drive with enhanced radial stiffness	DC Brushless with rolling element bearings	DC Brushless with rolling element bearings
Feedback Type	Motor Encoder	Motor Encoder	Rotary Encoder	Absolute Encoder
Speed Range	0-40rpm	0-40rpm	0-3000rpm	0-1000rpm
Load Capacity				8Kg
Maximum Inertial Load ²	N/A	N/A	N/A	2.0Kg*m ² @267rad/s ²
Positional Repeatability @ Motor	≤0.1arcmin	≤0.1arcmin	N/A	±1arcmin
Working Range	+110°, -55°	±180°	Continuous bi-directional	Continuous bi-directional
Radial Run-Out	Rotation of VP Setting Ball mounted in H Axis Chuck and rotated about the Virtual Pivot <40µm			<5µm
Axial Run-Out				<20µm

13.4 Contact

For more information, please visit our website (www.zeeko.co.uk) or contact us via the following:

Zeeko Ltd. | 4 Vulcan Court | Vulcan Way
 Coalville | Leicestershire | LE67 3FW | UK
 +44 1530 815 832
info@zeeko.co.uk
sales@zeeko.co.uk

² Maximum Inertial load in standard configuration including hydrodehn chuck. Variations may be possible with servo retuning – contact Zeeko Ltd. for advice